

AIWA
HI-FI Audio
Cassette Decks/CD Player

AIWA®





AD-F990B

AIWA's Finest Deck for State-of-the-art Sound Performance

The fabulous AD-F990B is AIWA's most advanced cassette deck, with features that not only ensure simple, foolproof operation, but also unmatched fidelity. Unquestionably the most superlative 3-head deck in its class, the AD-F990B offers advanced engineering for superior total performance.

Amorphous Combination Head

The AD-F990B features a head which promises to surpass almost every previous standard of top performance. Unlike most metals which have a uniform atomic configuration, amorphous alloy is a new non-crystalline material with nonspecific, non-directional atomic configuration. When utilized as head material, it is able to display such ideal characteristics as a high maximum magnetic flux density, outstanding signal linearity (due to lower coercivity), and minimal generation of electromagnetic noise. Add to this a remarkable hardness for extra durability, and you can understand why the AD-F990B delivers such superior performance.



Dolby HX Professional: A revolutionary new approach to the problems of recording bias

Not noise reduction but an entirely new way of processing signals, this sophisticated circuitry functions during all recordings but requires no processing during playback. For this reason, whether cassettes are recorded with or without Dolby noise reduction you'll have the advantage of full playback compatibility in any type of cassette equipment. HX stands for "Headroom Extension", and it operates during recording by means of a special circuit which dynamically adjusts bias levels in response to the input signals. This contributes to significant improvements in dynamic range, while at the same time making possible a naturally "flat" response in the upper frequencies. Because

the bias level is fixed in conventional cassette decks, they are inevitably handicapped by the phenomena of "self bias" and "mutual bias", resulting in inability to accurately reproduce high frequency signals above a certain volume level. Dolby HX Professional has been specifically designed to deal with this problem. By use of a servo circuit which functions independently in right and left stereo channels during recording, AIWA's new decks can ensure that ideal bias levels are applied at all times. Because this contributes to reducing easily-incurred high frequency tape saturation, you'll be amazed at the clarity and absence of distortion; a definite difference. If you plan to make tapes from digital program sources, AIWA's decks are also designed to take optimum advantage of the increased recording headroom offered by Dolby C noise reduction. Results of recordings in this mode are truly superb: with metal tape, the AD-F990B boasts a frequency response of 20 to 20,000Hz with signal/noise an outstanding 80dB (above 5kHz).

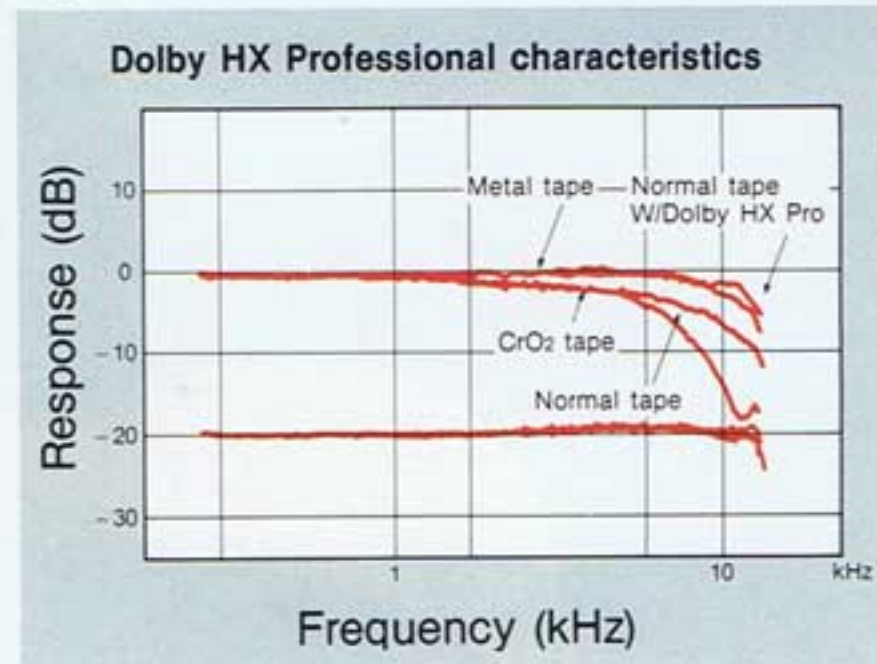

Auto Tape-Source Selector

Three-head decks normally require switching between TAPE and SOURCE for monitoring. The

AD-F990B is equipped with a special circuit that automatically switches to the user-preferred position. For greater control, manual switching is also possible.

Auto Noise Reduction Detector

Whenever you play a tape recorded on the AD-F990B it will switch to the correct NR setting (Dolby C/B/off) automatically.

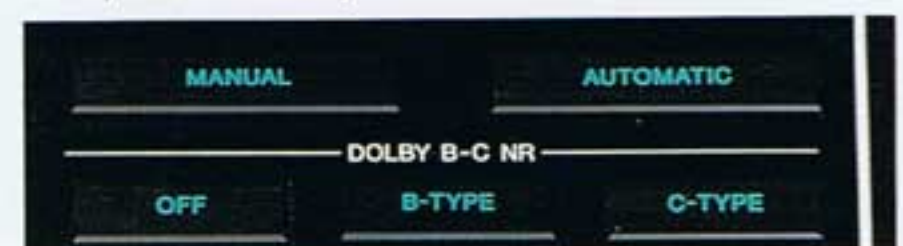

Auto Recording Level Control

When recording begins, the level is set to the ideal point for the type of tape in use, ensuring optimum recording results. Of course, manual setting is also possible.



Plus:

- DATA (Digital Automatic Tape Adaptation) system
- Flat "Keyboard" control panel
- ADMS (Auto-De-magnetizing System)
- Micro-grain surfaced dual capstan transport
- Intro-play facility
- All-mode tape remaining time display
- Memory Rewind and Repeat System
- Feather-touch electronic recording level control with position indicator
- Fluorescent multi-function display with peak hold
- Microphone jacks (rear panel)
- Auto Rec-mute
- Auto tape selector
- 1-program music sensor
- Switchable MPX filter (rear panel)
- Timer standby recording/playback



AD-F770B

Sophisticated Features for Superior 3-Head Sound Quality

Offering most of the features incorporated in the AD-F990B, this sophisticated 3-head deck's Dolby HX Professional and DATA circuitry ensure sound reproduction that outrivals any other model in its class. From AIWA's original flat "keyboard" control panel to the unique All-mode remaining tape time display, the AD-F770B is the kind of machine you can depend on for the best in cassette performance.

DATA (Digital Automatic Tape Adaptation)
Is your deck prevented from delivering its best performance with the tape you want to use? The fact is that only a deck like the AD-F770B can ensure ideal matching with every tape brand and formulation. DATA, AIWA's sophisticated built-in microcomputer system, "tests" each tape prior to recording and automatically adjusts bias,

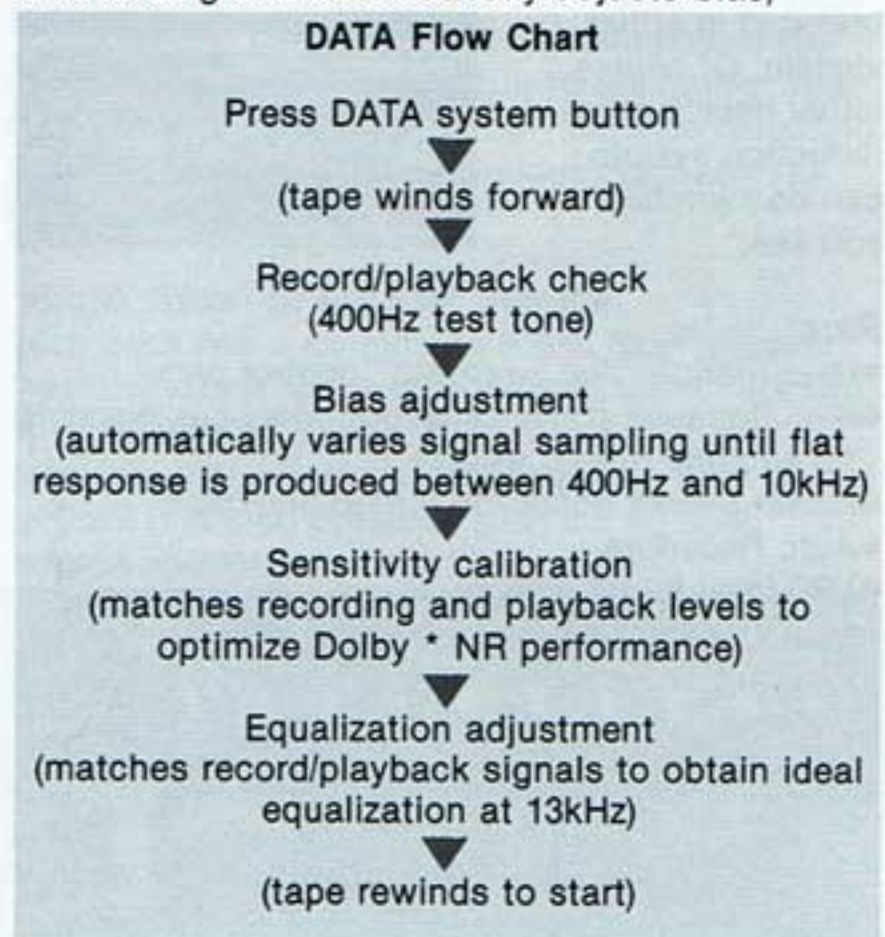

equalization and sensitivity to ideal levels—in only 16 seconds! Perfect tape compatibility is your assurance of perfect recordings with any tape.



Dolby HX Professional
Designed to raise cassette deck performance to the demanding levels required for digital audio sources, this circuitry provides high frequency signals with the ideal bias levels by servo control which automatically functions in response to self-bias and mutual bias levels. And absolutely no encoding is needed for playback, so you can enjoy these tapes anywhere!

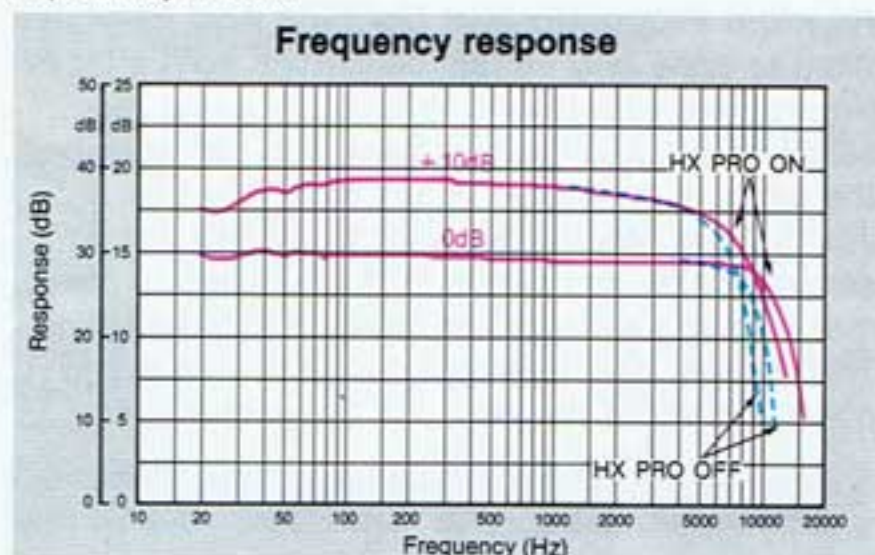

DX Combination Head
Designed for extra protection from uneven wear, the DX head employs a special laminated configuration of ultra-hard permalloy chips and epoxy resin. High flux density and superb signal linearity complement the low-noise construction.



ADMS—Auto De-Magnetizing System
An essential part of head maintenance, de-magnetizing used to be an awkward and time-consuming chore until AIWA introduced its original Auto De-magnetizing System (ADMS). This built-in oscillator circuitry functions in a matter of seconds to remove residual magnetic buildup from the heads each time the unit's power is turned on.



Micro-grain Surfaced Dual Capstan System
As a cassette plays from start to end, tape is constantly subjected to changes in winding torque due to increasing load on the take-up reel, and this can have a detrimental effect on the quality of playback signals. AIWA's exclusive Micro-grain dual capstans provide more positive cohesion between tape, capstan and pinchroller, thus minimizing modulation noise and resulting in exceptionally low levels of wow & flutter—an inaudible 0.025% (WRMS).

Memory Rewind and Repeat System
This allows repeat playback of any preselected tape segment you designate.



- Plus:**
- Fluorescent multi-function display with peak hold
 - All-mode tape remaining time display
 - Dolby B/C noise reduction
 - Intro-play selection preview
 - Memory rewind and repeat system
 - Auto Rec-mute
 - Auto tape selector
 - 1-program music sensor
 - Timer standby recording/playback
 - Switchable MPX filter (rear panel)
 - Stereo microphone inputs (rear panel)



AD-WX220

Double Deck with Four Times the Performance -dub tapes in 1/4 the playing time

The AD-WX220 is no ordinary double cassette deck. Why? Because it offers four times the performance. The AD-WX220 has a high-precision double speed drive which enables you to copy tapes in half the time. But there's more. Using the ALL-TRAC recording system, both sides of the tape can be copied simultaneously. Add it all together and it's the deck that copies your tapes four times faster than conventional double cassette decks. Together with microprocessor-assisted random program editing, tape dubbing operations are finished quickly and efficiently. Now that's extraordinary performance.

Exclusive ALL-TRAC Recording

Copying a 90 minute tape takes around 23 minutes, a 60 minute tape, just 15 minutes flat. Of course, single side and normal speed dubbing are also possible. The AD-WX220 gives you both speed and versatility. How does it work? AIWA's exclusive ALL-TRAC Recording system allows simultaneous dubbing of both sides of the tape. Just press the HIGH SPEED A + B button and your tape will be ready in one-fourth the normal playing time.

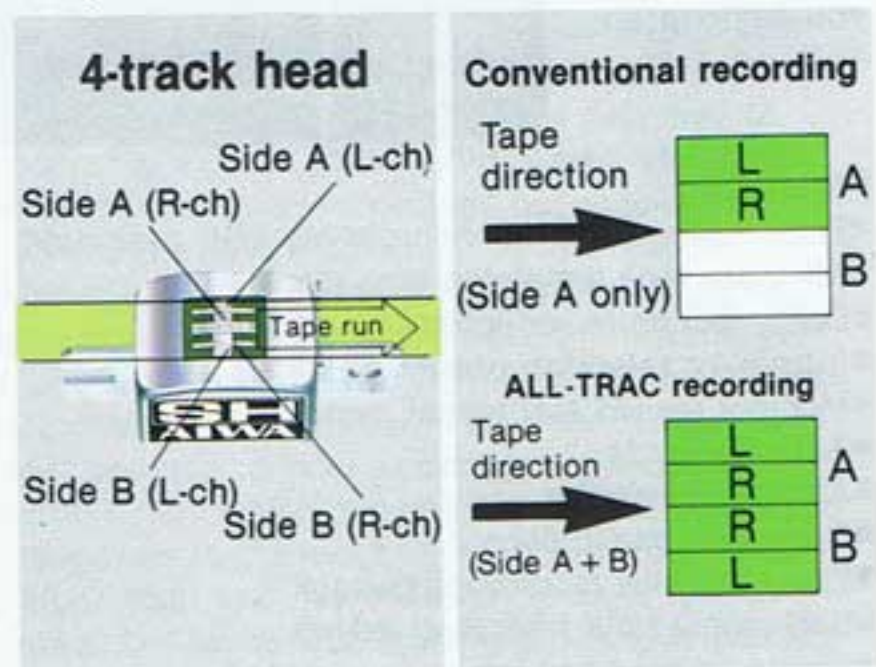

Synchro-dubbing—Three Different Ways

Even though the AD-WX220 has three different dubbing modes, operation is extremely simple because each mode has its own button. Thanks to AIWA's advanced microprocessor control, just a touch of the dubbing button of your choice is all it takes. No tricky adjustments or switching from side to side. Load the tapes, set the recording level sliders to the DUBBING LEVEL position, and everything's ready to go. Bias and equalization levels have already been set in both decks by the Auto Tape Selector, which adjusts automatically for Normal, CrO₂, and Metal position tapes. With such convenient operation, the AD-WX220 is halfway finished by the time ordinary double decks are ready to go.

Random Programmable Dubbing And Playback

Want to copy only certain selections from a tape? No problem with the AD-WX220. By using ten-selection programming buttons, you can specify the tunes to be copied in any order you like. Just set the program selector to the MS (music sensor) mode, and punch in the numbers of the master tape's songs in any order, up to 10 selections. This system even operates during double speed operation to get the job done far quicker than

ordinary "stop and search" tape editing necessary with conventional dubbing decks.

Music Sensor Operation

The music sensor function enables you to quickly cue and play back the song you want to hear from the beginning. With pushbutton convenience, it makes troublesome and time-consuming manual search operations unnecessary.

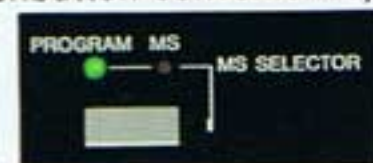

Random Dolby B/C NR setting in Decks I and II

To keep your tape copies as clear and noise-free as possible, AIWA has included Dolby B and C noise-reduction in both decks. In the normal speed dubbing mode, the NR system for each side can be independently switched to allow copying of tapes encoded in either system. Of course, either deck's noise reduction system can be switched as you like.



Plus:

- User-friendly "flat keyboard" control panel
- Simultaneous playback of both decks is possible for exciting mixing effects
- Music Sensor operation during playback
- Auto Rec-mute
- LED level meter display
- Selectable source headphone monitor
- Bias fine adjuster for Normal and CrO₂ tapes (±20%)

The AD-WX220 dubs tunes from one cassette to another in any order you select.

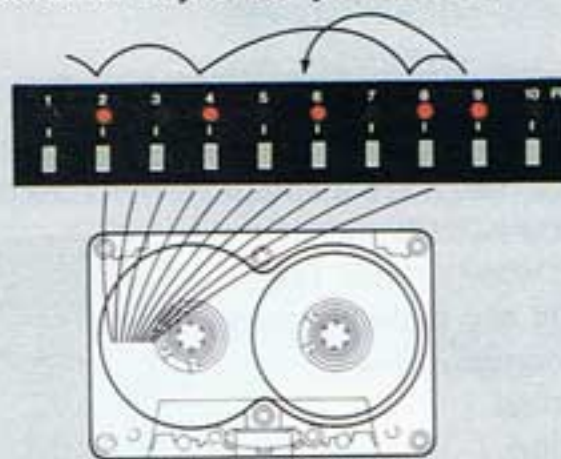

Recording order: 2-4-8-9-6 (1, 3, 5 & 7 are skipped)



AD-WX200

Truly Two Decks In One! -quick reverse recording on both sides

The AD-WX200 is the double deck you've been waiting for. It features the convenience of quick 0.3 second auto reverse—in both decks. Now you can record two tapes from an external source at the same time, in addition to normal or double speed dubbing from tape to tape. An 18-selection music sensor on deck I enables synchronized double-side "edit-dubbing" too. Plus, features like blank skip, continuous recording and playback, Dolby B and C noise reduction and more assure total versatility and top performance.

Quick Reverse Recording and Playback in Both Decks

AIWA's quick-reverse mechanism changes tape direction in only 0.3 seconds—so fast you can hardly hear it. A special photoelectronic sensor spots the end of the magnetic portion of the tape and activates the reverse mechanism before the leader-tape silence puts a stop to the music. This quick reverse operation not only extends recording time, but also enables continuous playback—in both Deck I and Deck II.

"Blank Skip" Shuts Out Silence

Each deck has a switchable Blank Skip function that fast forwards the tape when a blank segment of more than 12 seconds is detected. In the continuous playback mode, blank skip from Deck I to Deck II is also possible, even during auto reverse operation.

Continuous Recording of Two Full Tapes

This feature enables you to record both sides of a tape in Deck II, then automatically switch over to record both sides of a tape in Deck I. When C-90 tapes are used, that's 3 hours of continuous recording time—a great help for timed recording of long radio broadcasts.

Continuous Playback: Deck I to Deck II

When both sides of a tape in Deck I have finished, this function automatically starts playback in Deck II. This means you can enjoy playback of two full tapes without leaving your seat.

Synchro 18-selection Edit-dubbing: Start and stop with a single touch

Dubbing from tape to tape requires just a single touch of the synchro-dubbing control. To finish, just stop one deck, and the other deck comes to a stop simultaneously. There's also the added bonus of edit-dubbing from tape to tape. Just program the master tape in Deck I to play up to 9 selections on each side in any random order, and Deck II will record each selection, pausing during search operations after creating a 4-second blank on the tape.



Simultaneous Recording in Both Decks

Both Deck I and Deck II can be set to simultaneously record from an external source such as a turntable, tuner, or CD player. This feature permits the recording of two tapes at the same time.

Plus:

- AIWA's "flat keyboard" design with feather-touch IC logic controls
- Dolby B and C noise reduction
- Electronic tape counter for Deck II
- Auto tape selector in both decks
- Auto rec mute in both decks
- Timer REC/PLAY standby for unattended recording with an audio timer
- Sliding recording level control
- Two color 8-point LED peak level meter display
- Headphone jack



Flat keyboard control panel



AD-WX180

Quality Tape Dubbing in 1/4 the Time -AIWA's ALL-TRAC recording makes it happen.

The new AD-WX180 is an affordable double cassette deck featuring AIWA's popular ALL-TRAC recording system which enables synchronized tape-to-tape dubbing in just 1/4 the playing time. In addition to this great convenience are other advanced features, such as Dolby B & C noise reduction, AIWA's original flat keyboard operation panel with feather-touch full IC logic controls for the ultimate in operation ease, and a fine bias control which allows you to get optimum performance from Normal and CrO₂ tape formulations. Add it all up and you'll find the versatile AD-WX180 is an excellent choice in a double cassette deck.

Exclusive ALL-TRAC Recording

The AD-WX180 gives you both speed and versatility. Dubbing a 90 minute tape takes around 23 minutes, a 60 minute tape just 15 minutes flat. How does it work? AIWA's exclusive ALL-TRAC recording system allows simultaneous dubbing of both sides of the tape by using 4-track tape heads. Just load the master tape in Deck I and the blank tape in Deck II, press the HIGH SPEED A + B button, and your tape dub will be ready in one-fourth the playing time.

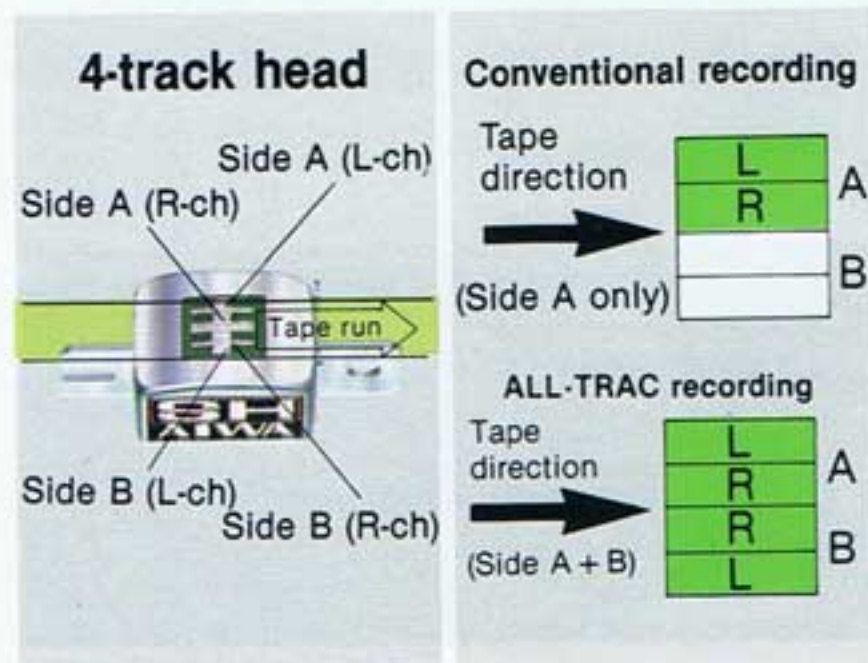

Synchro Dubbing Convenience

The AD-WX180 has three different dubbing modes, with simple one-touch operation of each. You can take your choice of:

- 1) high speed ALL-TRAC recording of both tape sides
 - 2) high speed recording of one tape side
 - 3) normal speed bubbing of one tape side
- Thanks to AIWA's advanced microprocessor control, just a touch of the dubbing mode button of your choice is all it takes. No tricky adjustments or switching from side to side. Just insert the tapes and you're all ready to go. Bias and equalization levels are set automatically by the auto tape selector in each deck. With such convenient dubbing operation, the AD-WX180 is halfway finished by the time ordinary double decks are ready to record.



Flat Keyboard Operation Panel

AIWA's innovative flat keyboard operation panel is a triumph in applying human engineering design concepts to audio equipment. All controls are laid out on a horizontally angled "keyboard" panel for easy operation of the full logic IC feather-touch controls.

Dolby B and C Noise Reduction

In addition to the widely popular Dolby B noise reduction system, the newer Dolby C system is included. It provides far more hiss reduction, while expanding the dynamic range of every tape you make. The result is clear, clean recordings that capture the dynamic performance of today's digital and high-level analog music sources.

Specially Designed Tape Heads for Superior Sound Performance

Playback sound quality, and the resulting fidelity of dubbed tapes, is enhanced by the type of head used in each deck. The playback-only deck makes use of a tape head which has been optimized for playback with a narrow 0.7μ gap, while the recording/playback deck's tape head features a wider 2.0μ gap for better overall performance.

Front Panel Fine Bias Control

Now you can get the best performance from Normal and CrO₂ tapes, without the worry of bias incompatibility. The fine bias control on the AD-WX180 gives you a ±20% range of adjustment that makes it easy to "fine tune" bias to get exactly the response that sounds best to you.



Plus:

- Cue and review
- Rec-mute facility (Deck II)
- Sliding-type recording level control
- 8-point 2-color LED peak level meter
- Rec/Play timer standby
- Tape counter with reset
- Headphone jack

AD-F640

The 3-Head Deck with Extra Features and Value

Impressive 3-head sound quality at a price that will please. That's AIWA's AD-F640. In addition to the 3-head design for ultimate recording/playback performance, it features dual capstan drive and Dolby HX professional circuitry that improves the quality of all your recordings, regardless of tape type used. Other features include A.D.M.S. and AIWA's flat keyboard operation panel for enhanced operation ease.

Three-head Design with AIWA's DX Combination Head

Both the recording and playback heads have been optimized for their specific purpose, and have been combined in AIWA's DX combination head. Its high flux density and superb signal linearity enable smooth and even response with minimal noise. The extra durable laminate construction incorporates ultra-hard permalloy chips and epoxy resin to prevent uneven wear, with an extra-tough sendust guard to resist head wear.

The Dolby HX Professional Difference

Not a form noise reduction, Dolby HX Professional circuitry improves high frequency response for the accurate recording of today's demanding digital audio sources. It uses independent L/R servo control circuits to provide high frequency signals with ideal bias levels during recording by responding to self-bias and mutual bias levels. Playback response with Normal tape is actually superior to that of CrO₂ tape recorded without Dolby HX Professional! And, you can enjoy this extra performance on any player because no special circuitry is needed for playback.

 DOLBY B-C NR HX PRO



Micro-Grain Surfaced Dual Capstan Transport

In addition to providing optimal tape-to-head contact that brings out the full potential of the three-head design, the dual capstan transport virtually eliminates the effects of tape load and tension variations by creating a "closed loop" in the section of tape that moves across the heads. Each of the capstans features AIWA's micro-grain surface, the result of a process which uniformly surfaces the capstan with millions of microscopic domes to ensure ideal tape adhesion between pinchroller and capstan. Further, the 2-motor drive reduces wow and flutter to inaudible levels.

A.D.M.S.—Auto De-Magnetizing System

Troublesome tape head demagnetizing is never

necessary with the AD-F640. Every time the deck is turned on, the A.D.M.S. circuit demagnetizes the tape heads in less than 1.5 seconds. Optimum frequency response is assured always, with minimum noise and distortion.

Plus:

- Dolby B & C noise reduction
- Electronic tape counter
- 2-color fluorescent peak level meters
- AIWA's flat keyboard operation panel
- Auto tape selector (Metal/CrO₂/Normal)
- Normal/CrO₂ tape bias fine adjuster ($\pm 20\%$)
- Auto/manual rec mute
- Switchable MPX filter for FM recording
- Stereo headphone jack

AD-F620

A New Standard in Basic 3-Head Performance

The AD-F620 sets a new standard in basic 3-head cassette deck performance. AIWA's DX Combination head, A.D.M.S., Dolby B & C noise reduction, and a host of other features combine to provide superior sound reproduction, making the AD-F620 a remarkable value.

High-Performance 3-Head Design

Just like the finest decks available, the AD-F620 has a three-head configuration with separate recording and playback heads. Each has been specifically designed for its task: the recording head has a wide 4 micron gap, while the playback head has a much narrower 1 micron gap. The result is sound reproduction far superior to that from two-head designs which must compromise with a single head for both recording and playback. The AD-F620's specifications tell the story: nearly flat 20—18,000Hz response (± 3 dB, metal tape). Another benefit of the three-head design is that it allows you to monitor the actual playback sound of the tape as you record, enabling precise manual adjustment of both recording level and bias.

AIWA's Flat Keyboard Design with Feather-Touch Control

The AD-F620's feather-touch full IC logic controls are laid out on the horizontally angled flat keyboard for greater visibility and ease of operation.

 DOLBY B-C NR



Dolby B & C Noise Reduction

Now standard on the best cassette decks, Dolby C noise reduction allows remarkably dynamic recordings with hardly any tape hiss. Using metal tape, the S/N ratio is an astounding 78dB (over 5kHz). The widely popular Dolby B system is also included for full compatibility when playing back tapes recorded in this format.

Fine Bias Adjuster

This control enables $\pm 20\%$ control of recording bias for Normal and CrO₂ tapes, allowing fine tuning during recording for best results.

Plus:

- A.D.M.S.—Automatic De-Magnetizing System
- Auto tape selector (Metal/CrO₂/Normal)
- Auto/manual rec mute
- 8-point L/R LED peak level meters
- Cue & review
- Timer Rec/Play standby
- Switchable MPX filter for FM recording
- Stereo headphone jack



AD-R460

The Affordable Advanced Deck with Quick 0.3 Sec. Reverse

AIWA's nearly imperceptible quick reverse recording and playback is featured in the new AD-R460, an affordable yet advanced cassette deck. The superbly engineered drive mechanism makes use of AIWA's "micro-grain" surfaced capstans, and two separate DC drive motors for precise operation. Plus, AIWA's innovative flat keyboard operation panel, with feather-touch IC logic controls for greater operating ease. With these features and more, the AD-R460 is certain to impress budget-minded audio enthusiasts everywhere.

AIWA's Radial Pivot Mechanism for Outstandingly Accurate 0.3 Sec. Reverse

The AD-R460 uses AIWA's accurate radial-pivot mechanism to turn the tape head 180° in the blink of an eye for astonishingly quick 0.3 second auto reverse. This same nearly instantaneous performance is assured during both recording and playback for virtually "seamless" transitions from one side of a tape to the other. And to eliminate the 10 to 15 second "blank time" caused by the tape leader in nearly all cassettes, a special photoelectric sensor spots the end of the magnetic portion of the tape and immediately activates the Radial-pivot reverse mechanism to keep the music going.

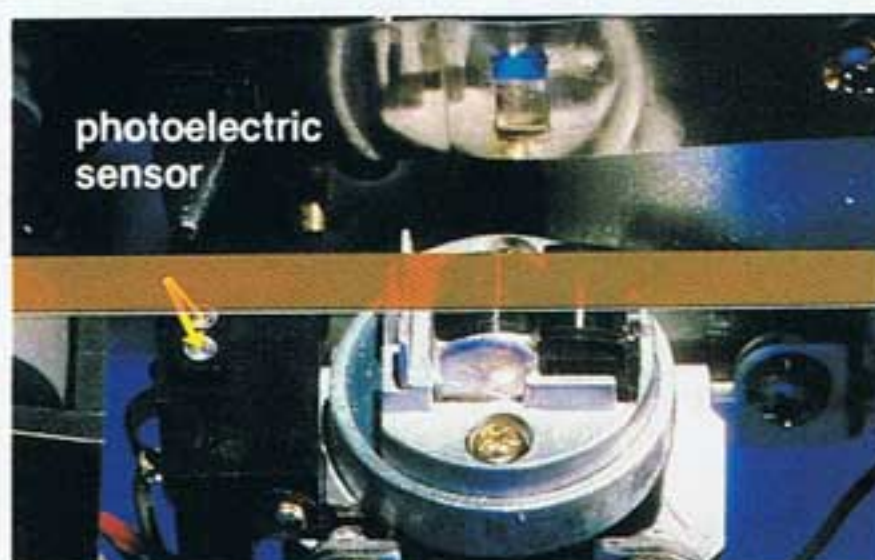

Precision cast from a super-hard alloy, AIWA's radial-pivot mechanism has been designed to withstand years and years of reverse operations with virtually no loss in alignment accuracy. On this mechanism is mounted AIWA's highly-acclaimed DX head which features superior linearity and low noise performance with excellent durability. The benefits of quick reverse are obvious. Now you can enjoy continuous recording on both sides of every tape you use. With a C-90 tape, that's a full 1-1/2 hours of non-stop music.

3-Way Reverse Operation

The AD-R460 has three mode selector buttons that enable continuous, one-cycle, or unidirectional operation. A highly visible reverse mode indicator shows your choice, while large arrows indicate the current tape direction.



Flat Keyboard Operation Panel

AIWA's innovative flat keyboard operation panel is a triumph in applying human engineering design concepts to audio equipment. All controls are laid out on a horizontally angled "keyboard" panel for easy operation of the feather-touch controls.

Feather-Touch Full Logic IC Controls with Cue & Review

Switching from one mode to another is especially easy, with no possibility of damage to the mechanism through improper operation. The feather-touch full logic IC controls respond instantly to a light touch, and are programmed with their own information to make it possible to switch directly from Fast

Forward to Rewind without pressing the Stop control. This design also enables Cue & Review operations for the speedy location by sound of desired musical passages without having to switch from the Play mode.

Dolby B and C Noise Reduction

In addition to the widely popular Dolby B noise reduction system, the newer Dolby C system is included. It provides far more hiss reduction, while expanding the dynamic range of every tape you make.



Front Panel Fine Bias Control

Optimum bias setting depends solely on the electromagnetic "character" of each tape formulation. Different brands of tape respond in slightly differing ways to the recording process. Conventional decks are equipped with bias setting switches that set the deck at an arbitrary level which may not enable perfect performance from the tape you're using. But with the fine bias control found on the AD-R460, you can get the best performance from Normal and CrO₂ tapes, without the worry of bias incompatibility. The fine bias control on the AD-R460 gives you a ±20% range of adjustment that makes it easy to "fine tune" bias to get exactly the response that sounds best to you.



Plus:

- Auto rec-mute
- Sliding-type recording level control
- Auto tape selector: Metal/CrO₂/Normal
- Rec/Play timer standby
- Soft oil-damped cassette eject
- Tape counter with reset
- Headphone jack

AD-F360

Simplified Operation with Superb Music Fidelity

Superb fidelity and easy operation in a simply designed 2-head deck are yours with the AD-F360. Its feather-touch controls are mounted on AIWA's flat keyboard operation panel for enhanced convenience, while Dolby B & C noise reduction and the fine bias control enable you to make better recordings. With that extra edge in features and fidelity, the AD-F360 represents a remarkable sound value.

Flat Keyboard Operation Panel with IC Logic Feather-Touch Control

AIWA's innovative flat keyboard operation panel arranges all the feather-touch controls on a horizontally angled panel so you can operate the AD-F360 easily with light downward taps of your finger. No more stooping to poke the controls like with conventional designs. The feather-touch controls respond instantly to a light touch, and are programmed so you can switch directly from mode to mode without having to press Stop in between.

Cue & Review

This feature makes it possible to find tape locations quickly by sound, in either direction, without switching from the Play mode.

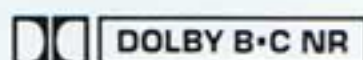
 DOLBY B·C NR



Dolby B & C Noise Reduction

Now a standard feature on the finest decks, Dolby C noise reduction dramatically reduces annoying tape hiss for clearer, more dynamic recordings. With metal tape, the S/N ratio is 78dB (over 5kHz), astonishing performance for a deck in this price range. The widely popular Dolby B system is also included for full compatibility when playing back tapes recorded in this format.

Fine Bias Control for CrO₂/Normal Tapes

Since recording characteristics may vary in different brands of tape, this control enables $\pm 20\%$ control

of recording bias for Normal and CrO₂ tapes, allowing you to fine tune the deck for the tape being used.

Plus:

- High performance DX head
- 2-color 8-point LED peak level meters
- Auto tape selector (Metal/CrO₂/Normal)
- Auto/manual rec mute
- Timer Rec/Play standby
- Tape counter with reset
- Stereo headphone jack

AD-F260

Flat Keyboard Panel and Advanced Features for Extra Value

AIWA's new AD-F260 combines the operation ease of our original flat keyboard operation panel with superb features to deliver excellent audio value in a quality 2-head deck. On the flat keyboard operation panel are soft-touch controls that respond smoothly, and impart a distinctive "user-friendly" feel. And, the AD-F260 boasts many features commonly found on more expensive decks, like Dolby B and C noise reduction, a high-performance DX head, and a fine bias control. A perfect blend of features, fidelity and quality, the AD-F260 is an unsurpassed value in top sound enjoyment.

Flat Keyboard Operation Panel

AIWA's innovative flat keyboard operation panel is a triumph in human engineering design. All controls are laid out on a horizontally angled "keyboard" panel so you can operate the AD-F260 easily by natural downward finger strokes, rather than pushing at the controls like with conventional designs.

Soft-Touch Controls with Cue & Review

All the drive functions are easily operated with the soft-touch controls, which respond smoothly and swiftly to your commands. Cue & review has been provided to enable you to locate desired musical passages by sound in either direction without having to switch from the Play mode.

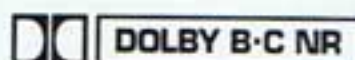
 DOLBY B·C NR



Dolby B and C Noise Reduction

In addition to the widely popular Dolby B noise reduction system, the newer Dolby C system is included. It provides far more hiss reduction, while expanding the dynamic range of every tape you make. The result is clear, clean recordings that capture the dynamic performance of today's digital and high-level analog music sources.

Front Panel Fine Bias Control

Now you can get the best performance from Normal and CrO₂ tapes, without the worry of bias incompatibility. The fine bias control on the AD-F260

gives you a $\pm 20\%$ range of adjustment that makes it easy to "fine tune" bias to get exactly the response that sounds best to you.

Plus:

- Rec-mute facility
- Sliding-type recording level control and level balance control
- High performance DX head
- Auto tape selector: Metal/CrO₂/Normal
- Rec/Play timer standby
- Tape counter with reset
- Headphone jack



AD-A70

AIWA's Auto Sorting System: Years Beyond the Double Deck Concept

Two of the most versatile auto reverse decks on the market still wouldn't give you the multi-function operation possibilities available from just one of AIWA's new Auto Sorting double cassette decks. Totally in a class by itself, the exciting new AD-A70 offers quick reverse recording and playback in BOTH decks to allow a wide variety of automatic, microprocessor-controlled operations like normal or double speed dubbing from up to 5 cassettes to 1 and random programmable playback from up to 5 cassettes. It's a fact: no other deck available gives you this much convenience and versatility. And that's just one more reason why AIWA is a leader in cassette technology.

What's Auto Sorting?

The answer can be found in Deck I. Inside there's an entirely new system that holds up to 5 cassettes in a special cassette block. Following the commands input with the front-panel controls, the mechanism actually "sorts" the tapes for random programmed playback and sequential timed recording.



Isn't it complicated to operate?

Not at all. Using the control buttons on the flat keyboard operation panel, it's easy to create your own music program. First, the program number is indicated by the brilliant display on the front panel of Deck I. Next, use the Up and Down buttons to specify the number of the tape (1 to 5) to be programmed. When the display indicates the desired tape, then press the Next button and select the tape side (A, B, or both). Press the Next button again and specify the number of the selection on the tape side (from 1 to 10). Now, all you do is press the Memory button and the selection information is set in the memory, and the next program is ready to set. You can select up to 15 programs, with simple one-by-one recall review by pressing the Memory button in succession. And during this review, you can individually change one or more programs as you like.



Quick Reverse Recording and Playback

Both Deck I and Deck II incorporate quick reverse mechanisms that function during recording and playback. An electronic photosensor spots the beginning of the leader tape, and reverses tape direction in just 0.3 seconds. Continuous, one-cycle, and uni-directional operation can be selected for Deck II.

15 Selection Random Programmed Playback

Up to 15 selections—or entire tape sides—from either side of up to five tapes can be selected for playback in any order you choose.



Random Program

Automatic Programmed Synchro-Dubbing: Normal or High-Speed

While Deck I "sorts" and plays the memory-programmed selections, Deck II can be set to synchro-record them. Deck II pauses during sort and search operations, and continues recording when the next selection is played. Select normal speed dubbing, or high-speed dubbing to finish in half the time.



Sequential Playback of 5 Tapes

Ideal for your next party, or anytime you want to enjoy extended music playback without interruption. Deck I can play both sides of up to 5 tapes without stopping—that's about 7-1/2 hours when C-90 tapes are used.

Continuous Timed Recording of up to 5 Cassettes (Deck I)

Using an audio timer, continuous recording on all 5 cassettes in Deck I is possible. Now you can record those extra-long broadcasts while you're away for later listening at your convenience. Recording is continuous from tape 1 through 5, with a short break in recording while the mechanism changes tapes. When using audio timers with multiple ON/OFF operations, Deck I can also be set to record up to 5 different programs, each on a separate tape. And, Deck II can also be set for timer-activated recording or playback.

Plus:

- AIWA's flat keyboard operation panel with feather-touch full IC logic controls
- Dolby B & C noise reduction system
- Electronic tape counter
- Blank skip
- Auto/manual Rec-mute
- Auto tape selector (Metal/CrO₂/Normal)
- Music Sensor (Deck II)



DX-1500

Go Digital with AIWA's Finest CD Player

All digital audio Compact Disc players give you stunning sound quality. But AIWA's DX-1500 gives you something more. Stunningly simple operation for the total enjoyment of the greatest advance in sound reproduction. No confusing operation sequence to remember. No long wait for the music to begin. Just great music when you want it. If that's why you're going digital, go for AIWA's DX-1500 CD player.

Hassle-free Playback

Just drop in a CD and press the Play button. The front-loading drawer closes automatically and playback begins.

Wireless Remote Control

From your favorite chair, you can order Play, Pause, Music Sensor, Skip, and Repeat operations with the supplied wireless remote controller.

16-track Programmable Playback

Up to 16 selections (including repeats) can be easily programmed into the DX-1500 for playback in any order you like.



Comprehensive FL Display

When you insert a CD, its contents and total playing time are shown on the brilliant FL display. During playback it shows the current track number and elapsed time. Touch the memory button and the programmed playback selections are indicated one by one.

Advanced 3-beam Laser Pickup

The DX-1500's advanced 3-beam laser pickup has been designed for positive and precise tracking of the "pit lane" encoded on Compact Discs. The main laser beam is guided by two sub-beams which track on either side, using highly responsive electronic servo circuitry to keep the main laser on course. The pickup assembly is driven by a linear motor for extremely fast access time.



3-beam laser tracking system

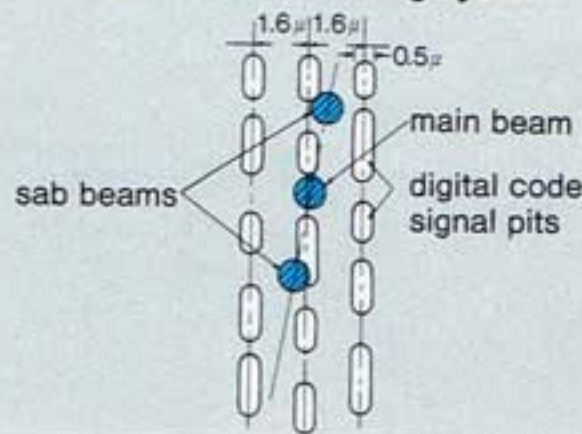

High Performance LSI's Improve Precision and Stability

The servo control, digital, and D/A (digital to analog) sections have been engineered onto specially designed LSI's (large scale integrated circuits) to simplify signal paths and improve the precision and reliability of signal transmission for faithful reproduction of Compact Discs. Along with specially chosen high-quality electronic components, they have been integrated onto a single circuit board which is insulated from the main chassis to avoid electromagnetic interference which can degrade sound quality.

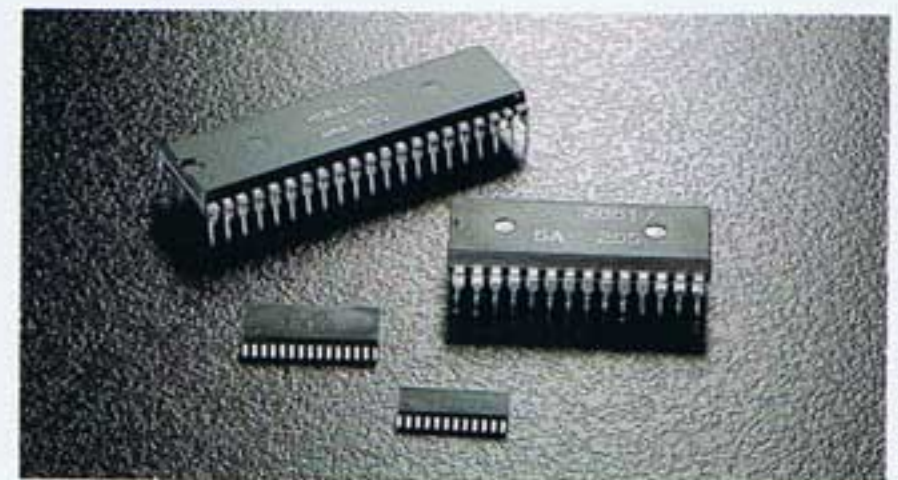

Plus:

- Forward and back skip with a single touch
- 3-way music repeat: entire disc/one track/programmed selections
- Manual cue & review (with sound); fast cueing (without sound) in both directions possible in the Pause mode
- Headphone jack with volume control

DX-1500 SPECIFICATIONS

Type	Compact Disc player
Number of channels	2 (stereo)
Frequency response	2Hz to 20kHz (±1dB)
Dynamic range	More than 90dB
Signal-to-noise ratio	More than 90dB (at 1kHz, 0dB)
Channel separation	More than 90dB (at 1kHz, 0dB)
T.H.D.	Less than 0.004% (at 1kHz)
Wow and flutter	Quartz crystal oscillator precision
Sampling frequency	44.1kHz
Quantization	16 bits linear/channel
Error correction	CIRC (Cross Interleave Reed Solomon Code)
Modulation	EFM (Eight to Fourteen Modulation)

Optical stylus
Output terminal
(LINE OUT)

Headphone out
Power source

Dimensions (W x H x D)
Weight

GaAlAs esmiconductor laser (λ = 780nm)
Terminal type: Pin jack
Maximum output level: 2V (50K ohms)
Load impedance: 10K ohms or more
12 mW (32 ohms)
H type: 120/220/240V, 50/60Hz
K & G types: 240V, 50Hz
E & Z types: 220V, 50Hz
U & C types: 120V, 60Hz
330 x 74 x 306.5mm
3.4kg

FEATURE COMPARISON TABLE

	No. of heads		Amorphous Alloy Combination Head	DX Head	Quick Reverse	Auto Sorting System (Play & Rec)	Double cassette high speed dubbing	Feather touch IC logic	Soft touch Transport	Micro grain surfaced capstan	Number of motors	Dolby FX Professional	Dolby C NR	DATA	Bias fine adjuster	Rec mute	Peak level display	Auto noise reduction detector	Auto recording level control	Auto Tape/Source selector	A.D.M.S.	All-mode remaining tape time display	Music sensor/Random play	Intro play	Blank skip	Electronic tape counter	
	3 head	2 head																									
AD-F990B	●	—	—	—	—	—	●	—	● (Dual)	2	●	●	●	(DATA)	● (Auto)	—	FL, W/Peak hold	●	●	●	●	●	1	●	—	●	
AD-F770B	●	—	● (Combi)	—	—	—	●	—	● (Dual)	2	●	●	●	(DATA)	● (Auto)	—	FL, W/Peak hold	—	—	—	●	●	1	●	—	●	
AD-WX220	—	●	—	—	—	● (1/4 time)	●	—	●	2+2	—	●	—	●	● (Auto)	—	8-point LED	—	—	—	—	—	9+9/ 9+9 random	—	—	—	
AD-WX200	—	●	—	● Both decks	—	●	●	—	—	2	—	●	—	—	● (Auto)	—	8-point LED	—	—	—	—	—	10/10 random	—	● Both decks	●	
AD-WX180	—	●	—	—	—	● (1/4 time)	●	—	—	2	—	●	—	●	● (Auto)	—	8-point LED	—	—	—	—	—	—	—	—	—	
AD-F640	●	—	● (Combi)	—	—	—	●	—	● (Dual)	2	●	●	—	●	● (Auto)	—	2-color FL	—	—	—	●	—	—	—	—	—	●
AD-F620	●	—	● (Combi)	—	—	—	●	—	—	1	—	●	—	●	● (Auto)	—	8-point LED	—	—	—	●	—	—	—	—	—	
AD-R460	—	●	—	●	●	—	●	—	—	1	—	●	—	●	● (Auto)	—	8-point LED	—	—	—	—	—	—	—	—	—	
AD-F360	—	●	—	●	—	—	●	—	—	1	—	●	—	●	● (Auto)	—	8-point LED	—	—	—	—	—	—	—	—	—	
AD-F260	—	●	—	●	—	—	●	—	—	1	—	●	—	●	● (Auto)	—	8-point LED	—	—	—	—	—	—	—	—	—	
AD-A70	—	●	—	● Both decks	●	●	●	—	—	4	—	●	—	—	● (Auto)	—	5-point LED	—	—	—	—	—	1 (Deck II) 15 random	—	●	●	

STEREO CASSETTE DECK SPECIFICATIONS

	AD-F990B	AD-F770B	AD-WX220	AD-WX200	AD-WX180	AD-F640	AD-F620	AD-R460	AD-F360	AD-F260	AD-A70	
POWER SOURCE	AC: 120/220/240V, 50/60Hz (H type) 240V, 50Hz (K & G types) 220V, 50Hz (E & Z types)	AC: 120/220/240V, 50/60Hz (H type) 240V, 50Hz (K & G types) 220V, 50Hz (E type)	AC: 120/220/240V, 50/60Hz (H type) 240V, 50Hz (K & G types) 220V, 50Hz (E type) 120V, 60Hz (C type)	AC: 120/220/240V, 50/60Hz (H type) 120/240V, 50/60Hz (K & G types) 220V, 50/60Hz (E type)	AC: 120/220/240V, 50/60Hz (H type) 240V, 50Hz (G type) 220V, 50/60Hz (E & Z types) 120V, 60Hz (C type)	AC: 120/220/240V, 50/60Hz (H type) 240V, 50Hz (K & G types) 220V, 50Hz (E & Z types) 120V, 60Hz (C type)	AC: 120/220/240V, 50/60Hz (H type) 240V, 50Hz (K & G types) 220V, 50Hz (E & Z types) 120V, 60Hz (C type)	AC: 120/220/240V, 50/60Hz (H type) 240V, 50Hz (K & G types) 220V, 50Hz (E & Z types) 120V, 60Hz (C type)	AC: 120/220/240V, 50/60Hz (H type) 240V, 50Hz (K & G types) 220V, 50Hz (E & Z types) 120V, 60Hz (C type)	AC: 120/220/240V, 50/60Hz (H type) 220V, 50/60Hz (E & Z types) 240V, 50/60Hz (K & G types)	AC: 120/220/240V, 50/60Hz (H type) 220V, 50/60Hz (E & Z types) 240V, 50/60Hz (K & G types)	AC: 120/220/240V, 50/60Hz (H type) 220V, 50/60Hz (E type)
DIMENSIONS (W x H x D)	420 x 110 x 286mm (16-9/16 x 4-3/8 x 11-5/16 inches)	420 x 110 x 286mm (16-9/16 x 4-3/8 x 11-5/16 inches)	420 x 110 x 323.4mm (16-9/16 x 4-3/8 x 12-3/4 inches)	420 x 110 x 323.4mm (16-9/16 x 4-3/8 x 12-3/4 inches)	420 x 110 x 297mm (16-9/16 x 4-3/8 x 11-3/4 inches)	420 x 110 x 295mm (16-9/16 x 4-3/8 x 11-5/8 inches)	420 x 110 x 295mm (16-9/16 x 4-3/8 x 11-5/8 inches)	420 x 110 x 295mm (16-9/16 x 4-3/8 x 11-5/8 inches)	420 x 110 x 295mm (16-9/16 x 4-3/8 x 11-5/8 inches)	420 x 116 x 278mm (16-9/16 x 4-5/8 x 11 inches)	330 x 107 x 348mm (13 x 4-1/4 x 13-5/8 inches)	
WEIGHT	5.5kg (12.1 lbs)	5.5kg (12.1 lbs)	5.6kg (12.3 lbs)	5.6kg (12.3 lbs)	4.8kg (10.6 lbs)	4.7kg (10.4 lbs)	4.2kg (9.3 lbs)	4.0kg (8.8 lbs)	4.0kg (8.8 lbs)	3.6kg (7.9 lbs)	6.0kg (13.2 lbs)	
TRACK	4-track, 2-channel											
TAPE SPEED	1-7/8 ips (4.8cm/sec)											
FREQUENCY RESPONSE												
OVU (Dolby C on)	Normal tape	20 - 12,000Hz (±3dB)	20 - 11,000Hz (±3dB)	—	—	—	—	—	—	—	—	
	CrO ₂	20 - 15,000Hz (±3dB)	20 - 14,000Hz (±3dB)	—	—	—	—	—	—	—	—	
	Metal tape	20 - 18,000Hz (±3dB)	20 - 17,000Hz (±3dB)	—	—	—	—	—	—	—	—	
-20VU	Normal tape	20 - 18,000Hz (±3dB)	20 - 17,000Hz (±3dB)	20 - 16,000Hz (±3dB)	20 - 14,000Hz	20 - 15,000Hz	20 - 16,000Hz (±3dB)	20 - 18,000Hz (±3dB)	20 - 13,000Hz (±3dB)	20 - 15,000Hz (±3dB)	20 - 15,000Hz (±3dB)	20 - 14,000Hz (±3dB)
	CrO ₂ tape	20 - 19,000Hz (±3dB)	20 - 18,000Hz (±3dB)	20 - 17,000Hz (±3dB)	20 - 15,000Hz	20 - 16,000Hz	20 - 19,000Hz (±3dB)	20 - 17,000Hz (±3dB)	20 - 16,000Hz (±3dB)	20 - 16,000Hz (±3dB)	20 - 14,000Hz (±3dB)	20 - 15,000Hz (±3dB)
	Metal tape	20 - 20,000Hz (±3dB)	20 - 19,000Hz (±3dB)	20 - 18,000Hz (±3dB)	20 - 16,000Hz	20 - 17,000Hz	20 - 20,000Hz (±3dB)	20 - 18,000Hz (±3dB)	20 - 17,000Hz (±3dB)	20 - 15,000Hz (±3dB)	20 - 17,000Hz (±3dB)	20 - 16,000Hz (±3dB)
S/N RATIO (Dolby B on) (Dolby C on, above 5kHz)	68dB (Dolby B, Metal) 80dB (Dolby C, Metal)	68dB (Dolby B, Metal) 80dB (Dolby C, Metal)	66dB (Dolby B, Metal) 78dB (Dolby C, Metal)	78dB (Dolby C, Metal)	78dB (Dolby C, Metal)	78dB (Dolby C, Metal)	78dB (Dolby C, Metal)	65dB (Dolby B, Metal) 78dB (Dolby C, Metal)	65dB (Dolby B, Metal) 78dB (Dolby C, Metal)	65dB (Dolby B, Metal) 78dB (Dolby C, Metal)	78dB (Dolby C, Metal)	
WOW AND FLUTTER (WRMS)	0.025%	0.025%	0.038%	0.06%	0.06%	0.028%	0.055%	0.065%	0.065%	0.09%	0.06%	
FORWARD AND REWIND TIME (C-60 TAPE)	60sec	60sec	80sec	90sec	90sec	70sec	70sec	90sec	90sec	105sec	90sec	
HEAD	REC/PB: Amorphous alloy Combination Head Erase: Double-gap Sendust Head	REC/PB: DX Combination Head (Sendust Guard) Erase: Double-gap Sendust Head	PB: Narrow gap 4-ch SH Head REC/PB: Wide gap 4-ch SH Head Erase: 2-track Ferrite Head	REC/PB: DX head x2 Erase: Double-gap Ferrite Head x2	PB: Narrow gap 4-ch SH Head REC/PB: Wide gap 4-ch SH Head Erase: 2-track Ferrite Head	REC/PB: DX Combination Head Erase: Double-gap Sendust Head	REC/PB: DX Combination Head Erase: Double-gap Sendust Head	REC/PB: DX Head Erase: Double-gap Ferrite Head	REC/PB: DX Head Erase: Double-gap Ferrite Head	REC/PB: DX Head Erase: Double-gap Ferrite Head	REC/PB: DX Head Erase: Double-gap Ferrite Head	REC/PB: DX Head x2 Erase: Double-gap Ferrite Head x2
MOTORS	DC servo motor x1 DC motor x1	DC servo motor x1 DC motor x1	DC servo motor x2 DC motor x2	DC servo motor x2	DC servo motor x2	DC servo motor x1 DC motor x1	DC motor x1	DC servo motor x1	DC servo motor x1	DC servo motor x1	DC servo motor x2 DC motor for Auto Sorting mechanism x2	
INPUT SENSITIVITY IMPEDANCE	MIC	1.0mV/ 200 ohms - 10k ohms	0.3mV/ 200 ohms - 10k ohms	0.25mV/ 200 ohms - 10k ohms	—	—	—	—	—	—	—	
	LINE IN	50mV/50k ohms										50mV/47k ohms
OUTPUT LEVEL IMPEDANCE	LINE OUT	0.41V/50k ohms or higher	0.41V/50k ohms or higher	0.41V/50k ohms	0.38V/47k ohms	0.41V/50k ohms	0.41V/50k ohms	0.41V/50k ohms	0.4V/50k ohms	0.4V/50k ohms	0.38V/47k ohms	
	HEADPHONE	1.5mW/8 ohms	1.5mW/8 ohms	0.8mW/8 ohms	0.8mW/8 ohms	0.8mW/8 ohms	0.8mW/8 ohms	0.8mW/8 ohms	0.8mW/32 ohms	0.8mW/32 ohms	0.5mW/8 ohms	

*Dolby and the double-D symbol are trademarks of Dolby Laboratories Licensing Corporation. *Specifications and design are subject to change without notice.
 •Please check the laws on copyright relating to recording from discs, radio or external tape for the country in which the machine is being used. *HX PROFESSIONAL ORIGINATED BY BANG & OLUFSEN